

ADT Smoke Alarm

Setup Guide

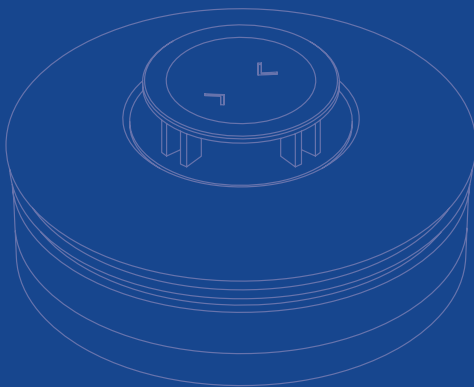

A Setup

1. Take the ADT Smoke Alarm to where you intend to mount it after setup.
 - Make sure you are within 350 feet from the ADT Security Hub. (Exact range depends on your home's construction, the environment, the position of the ADT Security Hub, and the position and number of other connected devices.)
 - Make sure that your ADT Security Hub is disarmed before connecting a new device.
 - Make sure that you only setup one new device at a time.
 - Do not remove the battery tab until you are ready to set up the detector.

2. Use the SmartThings app on your smartphone to select the "My Home" tab. Select "Things", and then "Add a Thing".
3. Use the SmartThings app to scan the QR code on the front of the alarm and then follow the on-screen instructions to complete setup.

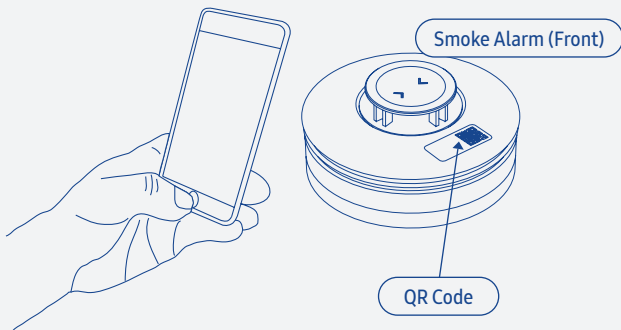

Setup

4. Remove the tab on the smoke alarm marked “Pull This Tab”. The yellow LED will blink once followed by a single blink of the red LED.

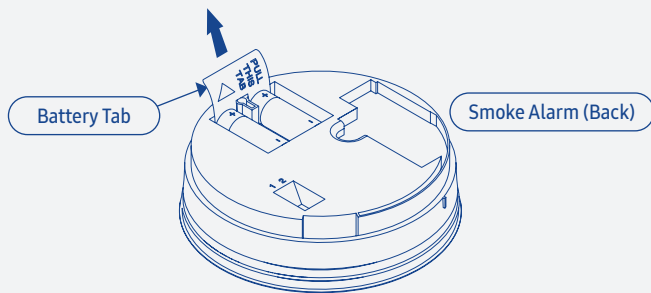

5. Remove the QR code from the front of the alarm and attach it inside the ADT Security Hub User Guide for future reference.

B Placement

Install the ADT Smoke Alarm in a place where the alarm can be heard easily. Ideally, per the National Fire Alarm Code (NFPA Standard 72), a smoke alarm should be installed:

- In all sleeping rooms and guest rooms.
- Outside of each separate dwelling unit sleeping area within 21 feet of any door to a sleeping room, the distance measured along a path of travel.
- On every level of a dwelling unit, including basements.

Placement

- On every level of a residential board and care occupancy (small facility), including basements and excluding crawl spaces and unfinished attics.
- In the living area(s) of a guest suite.
- In the living area(s) of a residential board and care occupancy (small facility).*

THIS EQUIPMENT SHOULD BE INSTALLED IN ACCORDANCE WITH THE NATIONAL FIRE PROTECTION ASSOCIATION'S STANDARD 72.**

* (Reprinted with permission from NFPA 72®, National Fire Alarm Code Copyright © 2007 National Fire Protection Association, Quincy, MA 02269. This reprinted material is not the complete and official position of the National Fire Protection Association, on the referenced subject which is represented only by the standard in its entirety.)

** (National Fire Alarm Code® and NFPA 72® are registered trademarks of the National Fire Protection Association, Inc., Quincy, MA 02269.)

Placement

The required number of smoke alarms might not provide reliable early warning protection for those areas separated by a door from the areas protected by the required smoke alarms.

For this reason, it is recommended that the householder consider the use of additional smoke alarms for those areas for increased protection. The additional areas include the basement, bedrooms, dining room, furnace room, utility room, and hallways not protected by the required smoke alarms.

The installation of smoke alarms in kitchens, attics (finished or unfinished), or garages is not normally recommended, as these locations occasionally experience conditions that can result in improper operation, or false alarms.

Placement

Important: Specific requirements for smoke alarm installation vary from state to state and from region to region. Check with your local Fire Department for current requirements in your area.

Sufficient smoke must enter your smoke alarm before it will respond. Your smoke alarm needs to be within 21 feet of the fire to respond quickly. Smoke alarms also need to be in positions where they can be heard throughout the property, so they can wake you and your family in time for everyone to escape.

A single smoke alarm will give some protection if it is properly installed, but most homes will require two or more to ensure that a reliable early warning is given. For recommended protection you should put individual smoke alarms in all rooms where fire is most likely to break out (apart from the kitchen and bathroom, where they should

be
loc
sou
tha
sta

Sim
sho
bet
the
hea
In h
ala
and

be placed nearby). Your first smoke alarm should be located between the sleeping area and the most likely sources of fire, e.g. living room, but it should not be more than 21 feet from the door to any room where a fire may start and block your escape from the house.

Single-Story Dwellings: If the premises is one story, you should put your first smoke alarm in a corridor or hallway between the sleeping and living areas. Place it as near to the living area as possible, but make sure that it can be heard loudly enough in the bedroom to wake someone. In houses with more than one sleeping area, smoke alarms should be placed between each sleeping area and the living area.

Placement

Multiple-Story Dwellings: If your home has more than one floor, at least one smoke alarm should be fitted on each level. Suggested locations shown below:

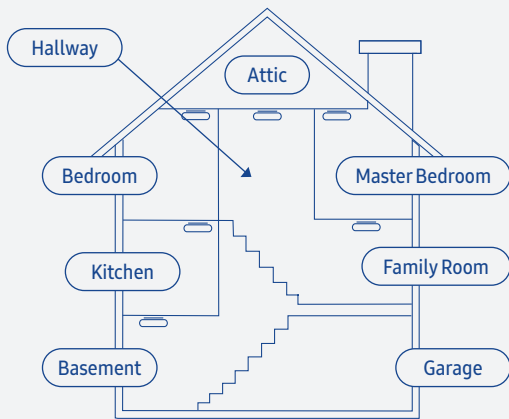

Re
you
wh
loc

The
nig
Con
in a
wh
bla

In a
ing
una
suc
Thi

Recommended Protection: Fire authorities recommend you put individual smoke alarms in or near all rooms where fire is most likely to break out (apart from the locations to avoid, e.g. bathrooms).

The living room is the most likely place for a fire to start at night, followed by the kitchen, and then the dining room. Consideration should be given to installing smoke alarms in any bedrooms where fires might occur, for instance, where there is an electrical appliance, such as an electric blanket or heater, or where the occupant is a smoker.

In addition, consideration should be also given to installing smoke alarms in any rooms where the occupant is unable to respond very well to a fire starting in that room, such as an elderly or sick person or a very young child. This device shall not be used with a detector guard.

Placement

For Ceiling Mounting:

Hot smoke rises and spreads out, so a central ceiling position is the recommended location. The air is “dead” and does not move in corners, therefore smoke alarms must be mounted away from corners. Keep at least 12 inches from walls and corners. Additionally, mount the unit at least 12 inches from any light fitting or decorative object which might prevent smoke entering the smoke alarm. Do not attach the detector to removable ceiling panels.

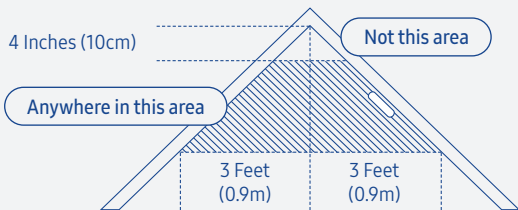

For Wall Mounting:

If ceiling mounting is impractical, smoke alarms may be mounted on a wall (if local ordinances permit), provided that:

- The top of the detection element is between 6 inches and 12 inches below the ceiling.
- The bottom of the detection element is above the level of any door openings.

Wall mounting should only be considered where close spaced beams or similar obstructions may preclude ceiling mounting. It is considered to be the responsibility of the installer or homeowner to determine if the presence of asbestos in the ceiling material would make ceiling mounting impractical.

Placement

On a sloping or peaked ceiling, install a smoke alarm within 24 inches of the peak (measured vertically). If this height is less than 24 inches the ceiling is regarded as being flat.

Smoke Alarms should face out in this position:

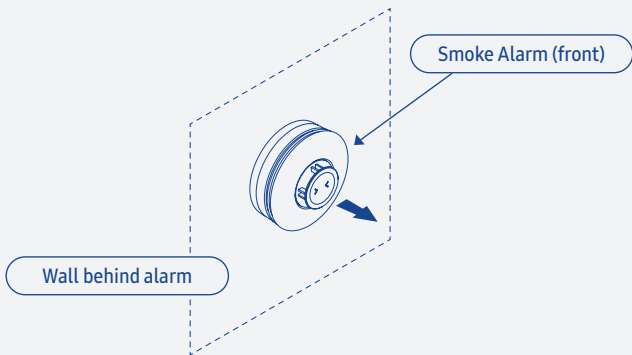

C Mounting

1. Install the mounting base using the two screws and anchors provided.

Ceiling Mount

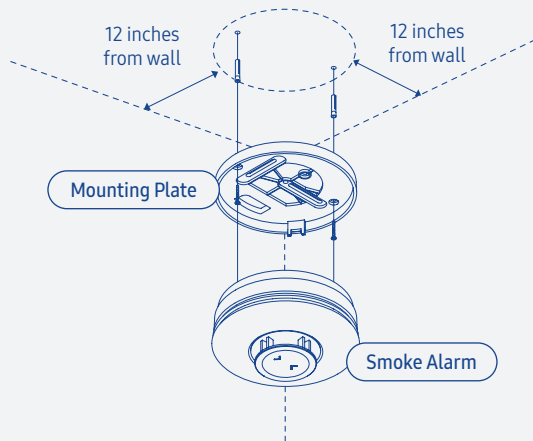

Mounting

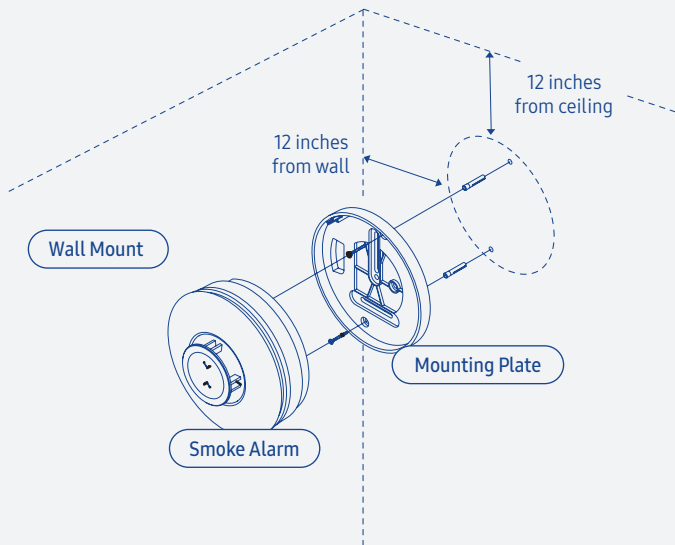

Mounting

2. Fit the alarm inside the base by aligning it over the base, then turn the alarm in a clockwise direction until it clicks into place.

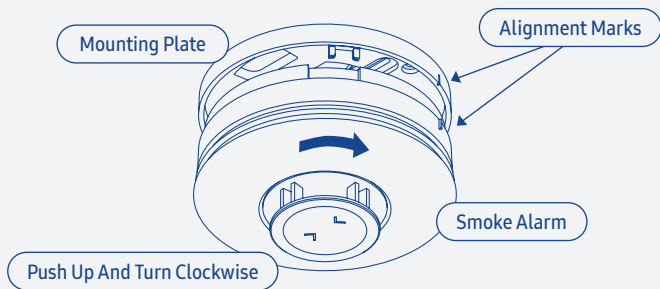

3. Test the alarm after completing the installation (see following section for details).

Mounting

WARNING: please read carefully and thoroughly.

- NFPA 72 states: Fire-warning equipment for residential occupancies are capable of protecting about half of the occupants in potentially fatal fires. Victims are often intimate with the fire, too old or too young, or physically or mentally impaired such that they cannot escape even when warned early enough that escape should be possible. For these people, other strategies such as protection-in-place or assisted escape or rescue would be necessary.
- Although smoke alarms can help save lives by providing an early warning of a fire, they are not a substitute for an insurance policy. Homeowners and renters should have adequate insurance to protect their properties.

Mounting

- A battery powered alarm must have a battery of the specified type, in good condition and installed properly.
- Smoke alarms cannot provide an audible alarm if smoke does not reach the detector. Therefore, smoke alarms may not sense fires starting in chimneys, walls, on roofs, on the other side of a closed door or on a different floor.
- Studies have shown that smoke and heat alarms may not awaken all sleeping individuals, and that it is the responsibility of individuals in the household that are capable of assisting others to provide assistance to those who may not be awakened by the alarm sound or those who may be incapable of safely evacuating the area unassisted.

Mounting

- The use of alcohol or drugs may also impair one's ability to hear the smoke alarm. For maximum protection, a smoke alarm should be installed in each sleeping area on every level of a home.
- Smoke alarms must be tested regularly to make sure the batteries and the alarm circuit are in good operating condition.
- Family Escape Plan: According to National Fire Protection Association (NFPA) there often is very little time between the detection of a fire and the time it becomes deadly. This interval can be as little as one or two minutes. Planning and practicing for fire conditions with a focus on rapid exit from the residence are important. Drills should be held so that all family members know the action to be taken.

- If the alarm is located outside the sleeping room or on a different floor, it may not wake up a sound sleeper.

Safety Tips:

- Practice using different ways out.
- Make a home escape plan. Draw a map of your home showing all doors and windows. Discuss the plan with everyone in your home.
- Know at least two ways out of every room, if possible. Make sure all doors and windows leading outside open easily.
- Practice your home fire drill at night and during the day with everyone in your home, twice a year.

Mounting

- Have an outside meeting place (like a tree, light pole, or mailbox) a safe distance from the home where everyone should meet.
- Teach children how to escape on their own in case you can't help them.
- Close doors behind you as you leave.

D

Test
a w
pla
AD

No
act
con
in t

D Testing

Test the ADT Smoke Alarm after installation and then on a weekly basis. Before initiating any of the below tests, place your ADT Security Hub in Walk Test Mode. See the ADT Security Hub User Guide for more details.

Note: If you have an ADT professional monitoring service activated, additional testing is required whenever you connect a new device. Follow the on-screen instructions in the SmartThings app to complete testing.

Testing

Alarm Operation Test: Push and hold the Test button on the alarm for a minimum of five seconds. The alarm will sound, and the red LED blink. The ADT Security Hub will display an alert for the smoke alarm.

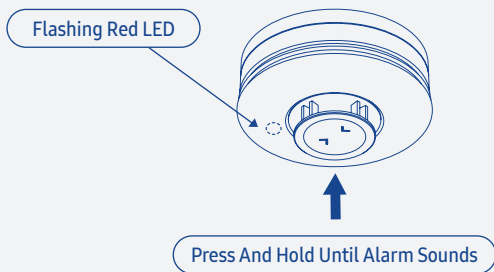

Direct Heat Test: Direct heat toward the alarm using a hair dryer. Be sure to hold the heat source about 12 inches from the alarm to avoid damaging the plastic. The alarm will reset once it cools down.

Smoke Test: Hold a match, canned smoke or other smoldering stick near the alarm with caution and gently blow smoke through the alarm until it goes off.

If the alarm fails to activate with any of these tests, clean it and repeat the tests. If cleaning does not restore the alarm to normal operation, it should be replaced. Check the date when the alarm should be replaced, which is given on the sidewall of the alarm.

YOUR ALARM SHOULD BE CLEANED AT LEAST ONCE A YEAR.

To clean your alarm, remove it from the mounting base. You can clean the interior by using a vacuum cleaner hose to blow or vacuum through the openings. The outside can be wiped with a dry cloth. After cleaning, reinstall and test your alarm as described above.

E Troubleshooting

If the alarm did not pair successfully with the ADT Security Hub, follow these instructions to reset it:

1. Remove the alarm from its mounting base.
2. Press and release the reset button twice.
3. Press and hold the button for 5 seconds until the red LED starts blinking quickly.

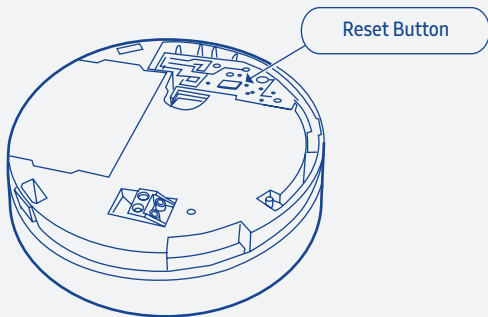

4.

5.

6.

If y
Ala
ass

Troubleshooting

4. Continue to press and hold the button until the red LED turns solid.
5. Release the button and after 5 seconds the red LED will begin to blink slowly.
6. Use the SmartThings app to complete setup.

If you're still having trouble connecting the ADT Smoke Alarm, please visit [SmartThings.com/Support-ADT](https://www.smartthings.com/Support-ADT) for assistance.

F Use

What You Hear / See

Siren at full volume,
red LED flashing.

No siren, red LED flash
every 8 seconds.

1 beep plus yellow LED flash
every 48 seconds.

2 beeps plus yellow LED flash
every 48 seconds.

3 beeps plus yellow LED flash
every 48 seconds.

What It Means

Sensing fire.

Smoke alarm hushed.

Batteries low.

Smoke and/or heat
sensor error.

Product expired
(10 years typical life).

Wh

If sa
imm

No a

Rep

Rep

Rep

What To Do

If safe, put out the source of the smoke. If unknown, get out of the house immediately. Follow appropriate fire safety guidelines at all times.

No action required.

Replace batteries.

Replace unit with same brand.

Replace unit with same brand.

G Suggestions

The ADT Smoke Alarm monitors for smoke and extreme temperatures in your home (heat above 135°F, or freeze below 40°F). When smoke or extreme heat is detected, the alarm siren sounds and a notification is sent to your ADT Security Hub.

Your ADT Security Hub can then send an alert to your smartphone, automate connected devices, or initiate optional ADT professional monitoring services (additional fees apply).

There are many ways you can use an ADT Smoke Alarm in your home:

- Put one in your living room and set it to initiate optional ADT professional monitoring service when smoke is detected in your home (additional fees apply).

•

•

•

No
dev
des
pro

Vis
spe

Suggestions

- Put one in your bedroom and set it to turn on connected lights when smoke is detected.
- Put one in your hallway and set it to turn off a connected thermostat to avoid spreading smoke through your home if a fire is detected.
- Put one in your home and set a connected camera to record video when smoke is detected (additional fees may apply).

Note: To ensure proper functioning, all connected devices must be configured correctly. This alarm is not designed to be interconnected with other manufacturers' products unless otherwise specified

Visit SmartThings.com/Welcome for more ideas, tips, and special offers.

H Works With SmartThings

SmartThings works with a wide range of connected devices, including lights, cameras, locks, thermostats, and sensors. It also works with the **Google Assistant** and **Amazon Alexa** so you can control your smart home with voice commands.

Look for the **Works with SmartThings** label next time you're buying a connected device for your home, or visit **SmartThings.com** to see the full list of compatible devices.





SmartThings, Inc., 665 Clyde Ave, Mountain View, CA 94043, USA. Information in this document is subject to change without notice. Copyright 2017 SmartThings, Inc. All rights reserved. ADT and the ADT logo are marks and/or registered marks of ADT. Unauthorized use is strictly prohibited. Revised 06/17.

P/N 10015711B